

KNIFE GATE VALVE DUCTILE IRON BODY

TECHNICAL PASSPORT

KNIFE GATE VALVE WITH HANDWHEEL RISING STEM DUCTILE IRON BODY - WAFER TYPE

VGA 4430-00

APPLICATION

The knife gate valve is particularly suitable for the most difficult applications.

Area of use: water treatment networks, pulp and paper industry, chemical plants, winemaking, cement works, pneumatic transport, storage.



Fluids: water, sewage, pulp, pasty products, powdery, granular, fibrous, abrasive and crystallizing.

GENERAL CHARACTERISTICS

Range: from DN50 to DN600.

- Knife Gate Valve on/off or regulation with rising stem.
- Molded monobloc body
- Unidirectional water tightness: Flow direction indicated on the body with an arrow.
- Installation between flanges ASME 150 Lbs.
- Small retention zone.
- Gate with a beveled cutting edge guided in the body with little backlash.
- Guaranteed closure, without risk of blockage.
- Standard polished gate, soft contact with the gaskets.
- Very resistant ductile iron packing flange avoids risks of breaks.
- Operating force reduced thanks to the elasticity of the gaskets.
- Pre-formed profiled sheet metal support plates from DN50 to DN300 for accessory or kit mounting.
- Full flow when fully opened, ensuring a high flow rate with low head loss.
- Flow regulation possible for pasty or abrasive fluids with installation of a deflector.

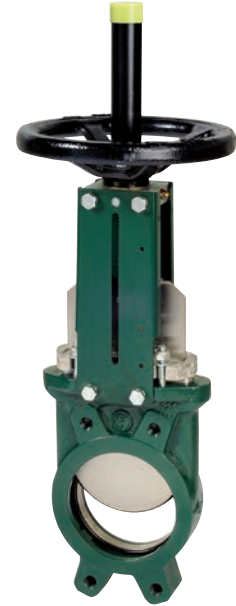

STANDARDS

Design	Manufacture according to the requirements of the European directive n° 2014/68/UE «Equipment under pressure» : modulate H. In option: product conform to European directive ATEX «ATmosphère EXplosive» n° 2014/34/UE.					
Face to face	Face to face dimension according to TECOFI standard					
Connection	Mounting between flanges in accordance with standard ASME B16.5 Class 150					
Tests	Pressure test according to standards EN12266-1, DIN 3230 and ISO 5208.					
	DN	Body	Seat	DN	Body	Seat
	DN50-250 :	15 bar	11 bar	DN300-450:	10.5 bar	7.7 bar
	DN500-600:	6 bar	4.4 bar			

PRODUCT APPROVALS



Tecofi France

83 rue Marcel Mérieux - 69960 Corbas
Tél. +33 (0)4 72 79 05 79 - Fax. +33 (0)4 78 90 19 19
E-mail : sales@tecofi.fr - www.tecofi.fr



KNIFE GATE VALVE DUCTILE IRON BODY

TECHNICAL PASSPORT

VGA 4430-00

CONSTRUCTION DN50 - DN300

The valves are coated with epoxy paint to protect them against corrosion

Component	Coating
Body (1)	Epoxy powder RAL 6005 150 microns
Support plate (8)	Liquid epoxy RAL 6005 70 microns
Gland packing (7)	
Handwheel (23)	Liquid epoxy RAL 9005 70 microns
Protection tube (24)	

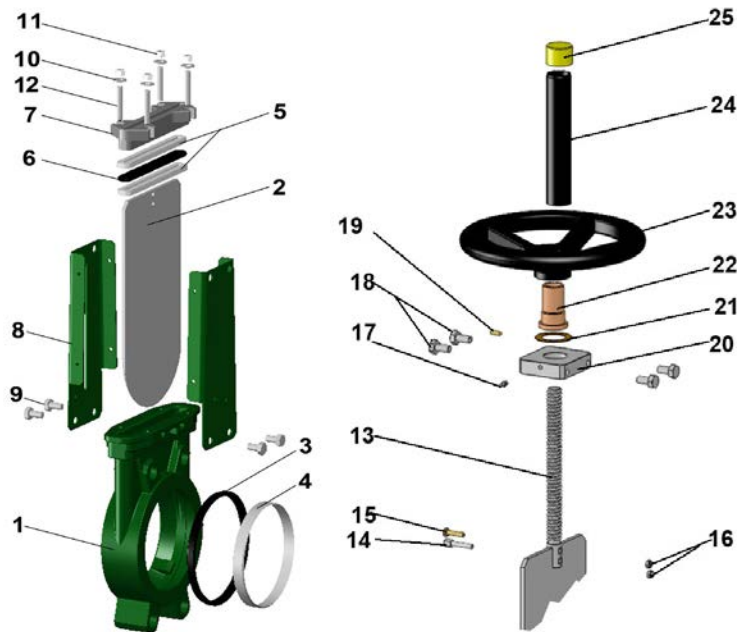

Pos.	Q-ty	Description	Material	Equivalences		
				DIN	ASTM	BS
1	1	Body	Ductile iron EN-GJS-500-7	GGG 50	A536 65-70-50-05	1563 EN-JS1050
2	1	Gate	Stainless steel X5CrNi 18-10	X5CrNi 18 10	A 182 AISI 304	1449-2 304 S15
3	1	Seat gasket	NBR			NBR
4	1	Support ring (1)	Stainless steel X5CrNi 18-10	X5CrNi 18 10	A 182 AISI 304	1449-2 304 S15
5	2	Packing	PTFE			
6	1	O-Ring	NBR			NBR
7	1	Packing gland	Ductile iron EN-GJS-400-15	GGG 40	A536 65-45-12	1563 EN-JS1030
8	2	Support plate	Steel			
9	4	Screw	Stainless steel A2-70			
10	4	Washer	Stainless steel A2-70			
11	4	Nut	Stainless steel A2-70			
12	4	Tie rod	Stainless steel A2-70			
13	1	Stem	Stainless steel 13% Cr	X12Cr13	AISI 410	
14	1	Detection screw	Stainless steel X5CrNi 18-10	X5CrNi 18 10	A 182 AISI 304	1449-2 304 S15
15	1	Screw	Stainless steel A2-70			
16	2	Nut	Stainless steel X5CrNi 18-10	X5CrNi 18 10	A 182 AISI 304	1449-2 304 S15
17	1	Greaser	Stainless steel X5CrNi 18-10	X5CrNi 18 10	A 182 AISI 304	1449-2 304 S15
18	4	Screw	Stainless steel A2-70			
19	1	Screw	Stainless steel A2-70			
20	1	Nut support	Zinc plated steel			
21	1	Support washer	Bronze CuSn5Zn8Pb5-C			
22	1	Nut	Bronze CuSn5Zn8Pb5-C			
23	1	Handwheel	Cast iron EN-GJL-250	GG 25	A48 class 40B	1452 Grade 250
24	1	Protection tube	Steel A45			
25	1	Plug	Polyurethane			

(1) - Parts missing on metal/metal sealing

Tecofi France

83 rue Marcel Mérieux - 69960 Corbas
Tél. +33 (0)4 72 79 05 79 - Fax. +33 (0)4 78 90 19 19
E-mail : sales@tecofi.fr - www.tecofi.fr



KNIFE GATE VALVE DUCTILE IRON BODY

TECHNICAL PASSPORT

VGA 4430-00

CONSTRUCTION DN350- DN600

The valves are coated with epoxy paint to protect them against corrosion

Component	Coating
Body (1)	Epoxy powder RAL 6005 150 microns
Support plate (8)	Liquid epoxy RAL 6005 70 microns
Gland packing (7)	
Handwheel (23)	Liquid epoxy RAL 9005 70 microns
Protection tube (24)	

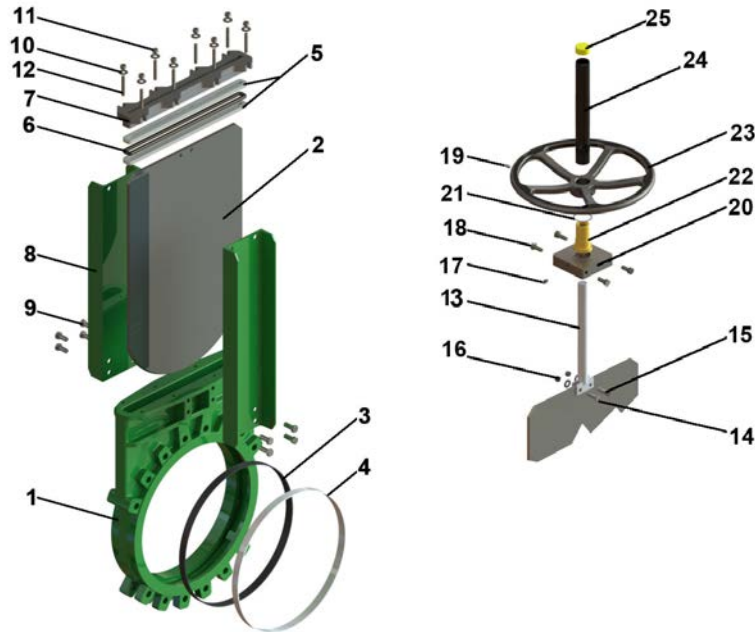

Pos.	Q-ty	Description	Material	Equivalences		
				DIN	ASTM	BS
1	1	Body	Ductile iron EN-GJS-500-7	GGG 50	A536 65-70-50-05	1563 EN-JS1050
2	1	Gate	Stainless steel X5CrNi 18-10	X5CrNi 18 10	A 182 AISI 304	1449-2 304 S15
3	1	Seat gasket	NBR			NBR
4	1	Support ring (1)	Stainless steel X5CrNi 18-10	X5CrNi 18 10	A 182 AISI 304	1449-2 304 S15
5	2	Packing	PTFE			
6	1	O-Ring	NBR			NBR
7	1	Packing gland	Ductile iron EN-GJS-400-15	GGG 40	A536 65-45-12	1563 EN-JS1030
8	2	Support plate	Steel			
9	12	Screw	Stainless steel A2-70			
10	8	Washer	Stainless steel A2-70			
11	8	Nut	Stainless steel A2-70			
12	8	Tie rod	Stainless steel A2-70			
13	1	Stem	Stainless steel 13% Cr	X12Cr13	AISI 410	
14	1	Detection screw	Stainless steel X5CrNi 18-10	X5CrNi 18 10	A 182 AISI 304	1449-2 304 S15
15	1	Screw	Stainless steel A2-70			
16	2	Nut	Stainless steel X5CrNi 18-10	X5CrNi 18 10	A 182 AISI 304	1449-2 304 S15
17	1	Greaser	Stainless steel X5CrNi 18-10	X5CrNi 18 10	A 182 AISI 304	1449-2 304 S15
18	4	Screw	Stainless steel A2-70			
19	1	Screw	Stainless steel A2-70			
20	1	Nut support	Zinc plated steel			
21	1	Support washer	Bronze CuSn5Zn8Pb5-C			
22	1	Nut	Bronze CuSn5Zn8Pb5-C			
23	1	Handwheel	Cast iron EN-GJL-250	GG 25	A48 class 40B	1452 Grade 250
24	1	Protection tube	Steel A45			
25	1	Plug	Polyurethane			

(1) - Parts missing on metal/metal sealing

Tecofi France

83 rue Marcel Mérieux - 69960 Corbas
Tél. +33 (0)4 72 79 05 79 - Fax. +33 (0)4 78 90 19 19
E-mail : sales@tecofi.fr - www.tecofi.fr



KNIFE GATE VALVE DUCTILE IRON BODY

TECHNICAL PASSPORT

VGA 4430-00

DIMENSIONS

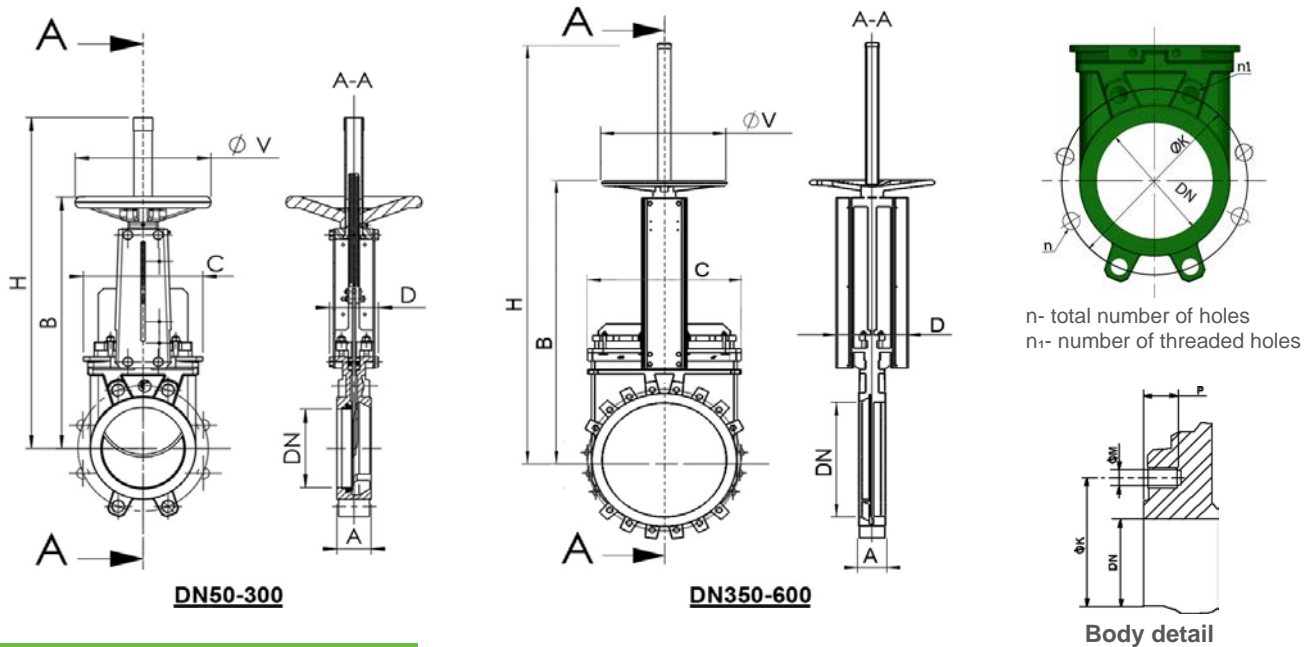

MOUNTING DIMENSIONS

DN		A	B	C	D	ϕV	H	Maximum pressure (bar)	n	n1- ϕM	P	ϕK	Weight (kg)
mm	inch												
50	2"	40	283	124	83	200	348	10	4	4 - 3/4	8	120.7	7,5
65	2 1/2"	40	308	139	83	200	388	10	4	4 - 3/4	8	139.7	9
80	3"	50	333	154	83	200	413	10	4	4 - 3/4	9	152.4	10
100	4"	50	378	174	83	200	488	10	8	4 - 3/4	9	190.5	11,5
125	5"	50	423	189	93	250	564	10	8	4 - 7/8	9	215.9	15,5
150	6"	60	474	220	93	250	635	10	8	4 - 7/8	10	241.3	18,5
200	8"	60	593	275	108	310	809	10	8	4 - 7/8	12	298.5	35
250	10"	70	685	326	108	310	946	10	12	8 - 1	12	362.0	47
300	12"	70	792	380	108	310	1118	7	12	8 - 1	19	431.8	61
350	14"	96	900	438	290	500	1282	7	12	10 - 1 1/8	20	476.3	117
400	16"	100	978	494	290	500	1441	7	16	10 - 1 1/8	24	539.8	151
450	18"	106	1105	547	290	500	1587	7	16	14 - 1 1/4	24	577.9	187
500	20"	110	1215	613	290	500	1809	4	20	14 - 1 1/4	24	635.0	205
600	24"	110	1418	716	290	500	2060	4	20	14 - 1 1/8	24	749.3	292

Dimension A - face to face according to TECOFI standard

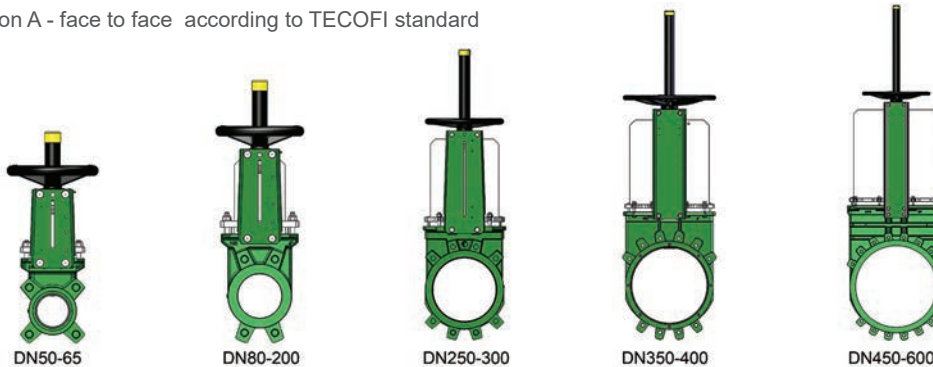

Tecofi France

83 rue Marcel Mérieux - 69960 Corbas
Tél. +33 (0)4 72 79 05 79 - Fax. +33 (0)4 78 90 19 19
E-mail : sales@tecofi.fr - www.tecofi.fr



KNIFE GATE VALVE DUCTILE IRON BODY

TECHNICAL PASSPORT

VGA 4430-00

WORKING CONDITIONS

Maximum working pressure: DN50-250 : 10 bar
DN300-450 : 7 bar
DN500-600 : 4 bar

Maximum working temperature : -10°C / +80°C (NBR joint in standard)

⚠ The above mentioned pressures are only valid if the direction of assembly indicated by the arrow on the valves is observed.

Upstream/downstream tightness



Elastomer
tightness

Metal/metal
tightness

Packing tightness

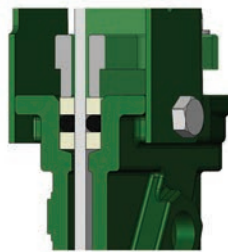

PTFE/Elastomer

Tightness in option

Tightness	maximum temperature
Metal/metal	Tmax : -10°C / +80°C
White NBR	Tmax : -10°C / +80°C
EPDM	Tmax : -10°C / +130°C
Silicone	Tmax : -10°C / +170°C
FPM (Type Viton®)	Tmax : -10°C / +170°C
PTFE	Tmax : +4°C / +170°C
CSM (Type Hypalon®)	Tmax : +4°C / +80°C

⚠ To ensure a satisfactory tightness, when using the PTFE gasket, the operating pressure must be at least 1 bar.

FLOWS

Kv of valves (m³/h)

DN		Operating stroke, %									
mm	inch	10%	20%	30%	40%	50%	60%	70%	80%	90%	100%
50	2"	1,41	7,57	18,4	33,27	52,61	74,78	98,45	120,81	149,53	161,66
65	2"1/2	2,41	8,58	25,4	49,32	85,77	121,51	167,85	219,67	287,45	317,77
80	3"	3	13,1	46,66	79,57	122,11	199,58	276,85	359,84	432,49	461,98
100	4"	3,86	33,06	75,62	125,01	206,17	311,72	474,43	681,36	865,17	993,21
125	5"	19,64	47,05	107,47	177,8	295,95	444,71	675,13	973,05	1231,14	1385,15
150	6"	28,88	104,25	181,37	281,61	418,76	614,83	884,79	1177,11	1482,44	1613,77
200	8"	24,04	141,73	251,71	418,72	514,76	785,11	1227,16	1982,56	2491,22	2783,27
250	10"	115,44	367,52	693,84	1141,65	1634,09	2342,79	3243,71	3960,67	5336,19	5951,8
300	12"	103,12	535,87	1023,55	1619,5	2441,26	3508,29	4553,83	6339,29	7862,36	8373,88
350	14"	218,4	725,8	1323	2173,2	3294,8	4914,3	7120,9	11415,3	19105,4	24890,7
400	16"	389,1	1150,1	2024,4	3130,9	4669,6	7009,1	10355,2	16014,2	22600,5	26497,7
450	18"	402,7	1287,3	2402,9	3803,4	5686,8	8247,3	12248,7	17298,5	26403,9	29485
500	20"	617	1611,1	2935,9	4625,8	7054,7	10438,9	15446	23582,8	35107,4	42784

Tecofi France

83 rue Marcel Mérieux - 69960 Corbas
Tél. +33 (0)4 72 79 05 79 - Fax. +33 (0)4 78 90 19 19
E-mail : sales@tecofi.fr - www.tecofi.fr

