

KNIFE GATE VALVE STAINLESS STEEL BODY

TECHNICAL PASSPORT

KNIFE GATE VALVE WITH HANDWHEEL RISING STEM STAINLESS STEEL BODY - WAFER TYPE PN10

VG 6400-00

APPLICATION

The knife gate valve is particularly suitable for the most difficult applications.

Area of use: water treatment networks, pulp and paper industry, chemical plants, winemaking, cement works, pneumatic transport, storage.



Fluids: water, sewage, pulp, pasty products, powdery, granular, fibrous, abrasive and crystallizing.

GENERAL CHARACTERISTICS

Range: DN50 to DN600.

- Knife Gate Valve on/off or regulation with rising stem.
- Molded monobloc body
- Unidirectional water tightness: Flow direction indicated on the body with an arrow.
- Installation between flanges ISO PN10.
- Small retention zone.
- Gate with a beveled cutting edge guided in the body with little backlash.
- Guaranteed closure, without risk of blockage.
- Standard polished gate, soft contact with the gaskets.
- Very resistant stainless steel packing flange avoids risks of breaks.
- Operating force reduced thanks to the elasticity of the gaskets.
- Pre-formed profiled sheet metal support plates from DN50 to DN300 for accessory or kit mounting.
- Full flow when fully opened, ensuring a high flow rate with low head loss.
- Flow regulation possible for pasty or abrasive fluids with installation of a deflector.

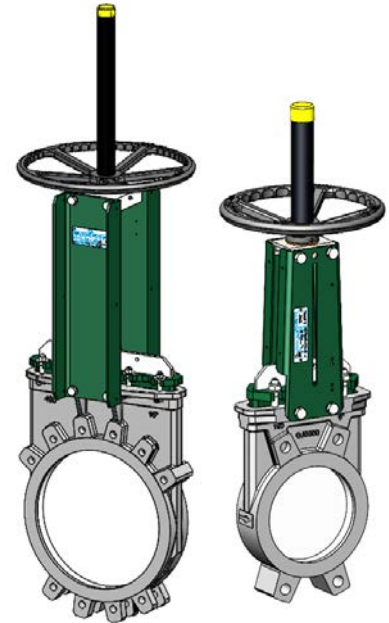

STANDARDS

Design	Manufacture according to the requirements of the European directive n° 2014/68/UE «Equipment under pressure» : modulate H.					
	In option: product conform to European directive ATEX «ATmosphère EXplosive» n° 2014/34/UE.					
Face to face	Face to face dimension according to TECOFI standard					
Connection	Mounting between flanges in accordance with EN1092-2 and ISO 7005-1 : ISO PN10					
Tests	Pressure test according to standards EN12266-1, DIN 3230 and ISO 5208.					
	DN	Body	Seat	DN	Body	Seat
	DN50-250 :	15.4 bar	11 bar	DN300-450:	12.6 bar	7.7 bar
	DN500-600:	7.2 bar	4.4 bar			

PRODUCT APPROVALS



Tecofi France

83 rue Marcel Mérieux - 69960 Corbas
Tél. +33 (0)4 72 79 05 79 - Fax. +33 (0)4 78 90 19 19
E-mail : sales@tecofi.fr - www.tecofi.fr



KNIFE GATE VALVE STAINLESS STEEL BODY

TECHNICAL PASSPORT

VG 6400-00

CONSTRUCTION

Coatings applied on the valve :

Component	Coating
Support plate (8)	Liquid epoxy RAL 6005 70 microns
Handwheel (21)	Liquid epoxy RAL 9005 70 microns
Protection tube (22)	Liquid epoxy RAL 6005 70 microns

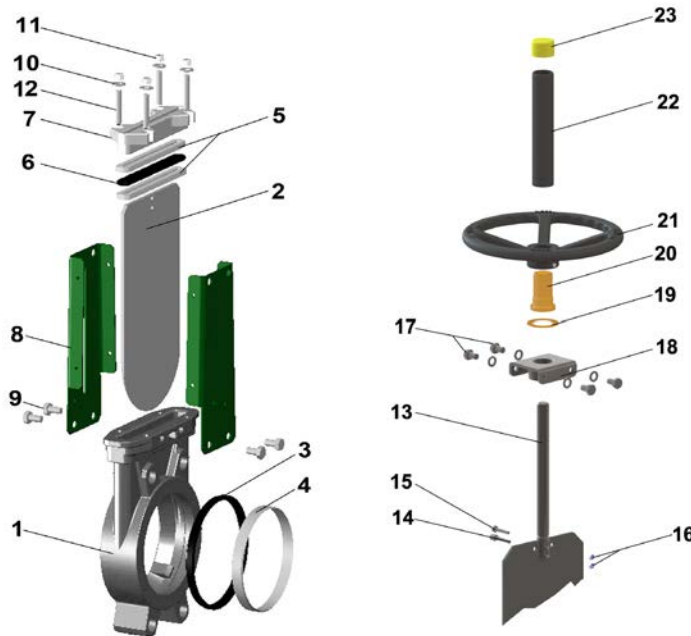

Pos.	Q-ty	Description	Material	Equivalences		
				DIN	ASTM	BS
1	1	Body	Stainless steel GX5CrNiMo 19-11-2	G-X6CrNiMo18 10	A 351 grade CF8M	316 C16
2	1	Gate	Stainless steel X2CrNi 17-12-2	X2CrNiMo17-13-2	A 182 AISI 316L	1449-2 316 S11
3	1	Seat gasket	EPDM			
4	1	Support ring (1)	Stainless steel X5CrNi 18-10	X5CrNiMo18 10	A 182 AISI 316	1449-2 316 S16
5	2	Packing	PTFE			
6	1	O-Ring	EPDM			
7	1	Packing gland	Stainless steel GX5CrNiMo 19-11-2	G-X6CrNiMo18 10	A 351 grade CF8M	316 C16
8	2	Support plate	Steel			
9	4	Screw	Stainless steel A2-70			
10	4	Washer	Stainless steel A2-70			
11	4	Nut	Stainless steel A2-70			
12	4	Tie rod	Stainless steel A2-70			
13	1	Stem	Stainless steel 13% Cr	X12Cr13	AISI 410	
14	1	Detection screw	Stainless steel X5CrNi 18-10	X5CrNi 18 10	A 182 AISI 304	1449-2 304 S15
15	1	Screw	Stainless steel A2-70			
16	2	Nut	Stainless steel X5CrNi 18-10	X5CrNi 18 10	A 182 AISI 304	1449-2 304 S15
17	1	Screw	Stainless steel A2-70			
18	1	Nut support	Zinc plated steel			
19	1	Support washer	Bronze CuSn5Zn8Pb5-C			
20	1	Nut	Bronze CuSn5Zn8Pb5-C			
21	1	Handwheel	Cast iron EN-GJL-250	GG25	A48 class 40B	1452 Grade 250
22	1	Protection tube	Steel A45			
23	1	Plug	Polyurethane			

(1) - Parts missing on metal/metal sealing

Tecofi France

83 rue Marcel Mérieux - 69960 Corbas
Tél. +33 (0)4 72 79 05 79 - Fax. +33 (0)4 78 90 19 19
E-mail : sales@tecofi.fr - www.tecofi.fr



KNIFE GATE VALVE STAINLESS STEEL BODY

TECHNICAL PASSPORT

VG 6400-00

CONSTRUCTION

Coatings applied on the valve :

Component	Coating
Support plate (8)	Liquid epoxy RAL 6005 70 microns
Handwheel (22)	Liquid epoxy RAL 9005 70 microns
Protection tube (23)	Liquid epoxy RAL 9005 70 microns

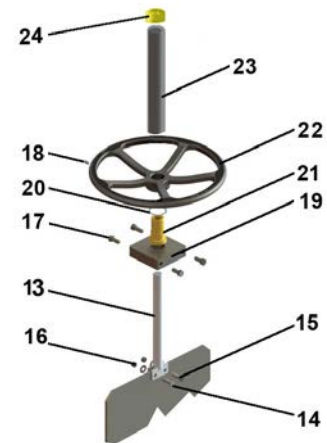
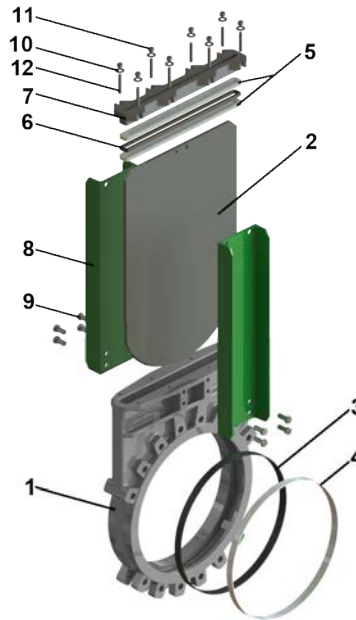

Pos.	Q-ty	Description	Material	Equivalences		
				DIN	ASTM	BS
1	1	Body	Stainless steel GX5CrNiMo 19-11-2	G-X6CrNiMo18 10	A 351 grade CF8M	316 C16
2	1	Gate	Stainless steel X2CrNi 17-12-2	X2CrNiMo17-13-2	A 182 AISI 316L	1449-2 316 S11
3	1	Seat gasket	EPDM			
4	1	Support ring (1)	Stainless steel X5CrNiMo 17-12-2	X5CrNiMo18 10	A 182 AISI 316	1449-2 316 S16
5	2	Packing	PTFE			
6	1	O-Ring	EPDM			
7	1	Packing gland	Stainless steel GX5CrNiMo 19-11-2	G-X6CrNiMo18 10	A 351 grade CF8M	316 C16
8	2	Support plate	Steel			
9	12	Screw	Stainless steel A2-70			
10	8	Washer	Stainless steel A2-70			
11	8	Nut	Stainless steel A2-70			
12	8	Tie rod	Stainless steel A2-70			
13	1	Stem	Stainless steel 13% Cr	X12Cr13	AISI 410	
14	1	Detection screw	Stainless steel X5CrNi 18-10	X5CrNi 18 10	A 182 AISI 304	1449-2 304 S15
15	1	Screw	Stainless steel A2-70			
16	2	Nut	Stainless steel X5CrNi 18-10	X5CrNi 18 10	A 182 AISI 304	1449-2 304 S15
17	4	Screw	Stainless steel A2-70			
18	1	Screw	Stainless steel A2-70			
19	1	Nut support	Zinc plated steel			
20	1	Support washer	Bronze CuSn5Zn8Pb5-C			
21	1	Nut	Bronze CuSn5Zn8Pb5-C			
22	1	Handwheel	Cast iron EN-GJL-250	GG25	A48 class 40B	1452 Grade 250
23	1	Protection tube	Steel A45			
24	1	Plug	Polyurethane			

(1) - Pièces non présentes sur étanchéité métal/métal

Tecofi France

83 rue Marcel Mérieux - 69960 Corbas
Tél. +33 (0)4 72 79 05 79 - Fax. +33 (0)4 78 90 19 19
E-mail : sales@tecofi.fr - www.tecofi.fr



KNIFE GATE VALVE STAINLESS STEEL BODY

TECHNICAL PASSPORT

VG 6400-00

DIMENSIONS

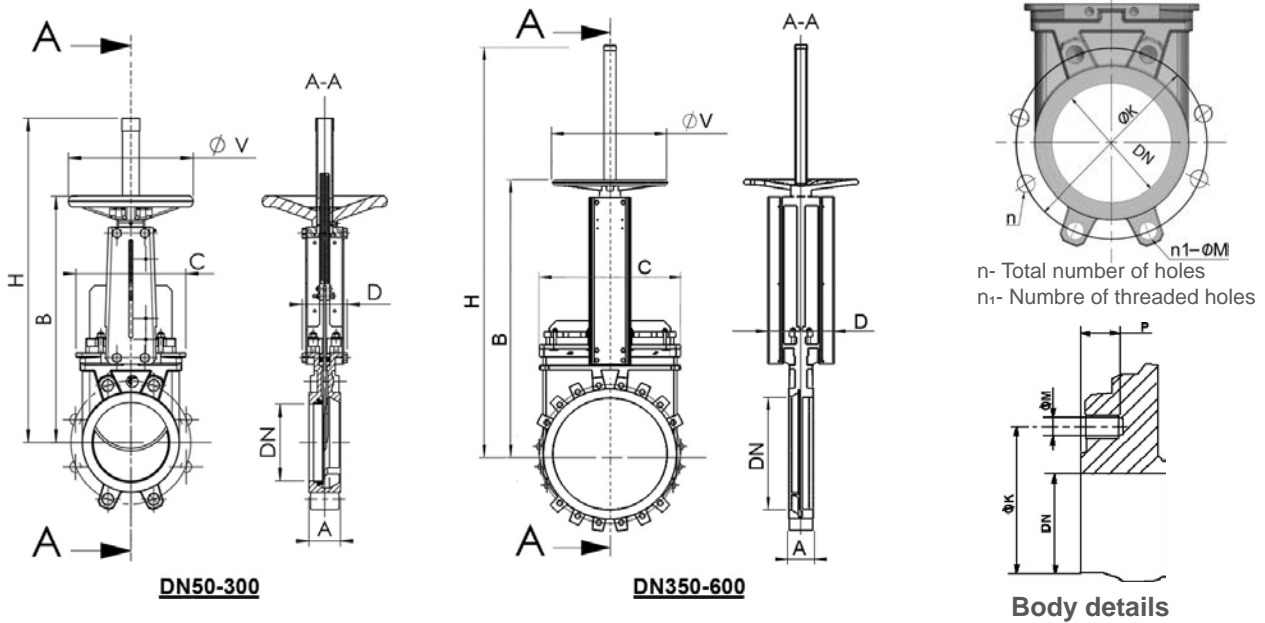

MOUNTING DIMENSIONS

DN		A	B	C	D	Ø V	H	Maximum pressure (bar)	n	n-ØM	P	ØK	Weight (kg)
mm	inch												
50	2"	40	283	124	83	200	348	10	4	4xM16	8	125	7,5
65	2 1/2"	40	308	139	83	200	388	10	4	4xM16	8	145	9
80	3"	50	333	154	83	200	413	10	8	4xM16	9	160	10
100	4"	50	378	174	83	200	488	10	8	4xM16	9	180	11,5
125	5"	50	423	189	93	250	564	10	8	4xM16	9	210	15,5
150	6"	60	474	220	93	250	635	10	8	4xM20	10	240	18,5
200	8"	60	593	275	108	310	809	10	8	4xM20	12	295	35
250	10"	70	685	326	108	310	946	10	12	8xM20	12	350	47
300	12"	70	792	380	108	310	1118	7	12	8xM20	19	400	61
350	14"	96	900	438	290	500	1282	7	16	10xM20	20	460	117
400	16"	100	978	494	290	500	1441	7	16	10xM24	24	515	151
450	18"	106	1105	547	290	500	1587	7	20	14xM24	24	565	187
500	20"	110	1215	613	290	500	1809	4	20	14xM24	24	620	205
600	24"	110	1418	716	290	500	2060	4	20	14xM27	24	725	292

Face to face dimension «A» in accordance with TECOFI standard

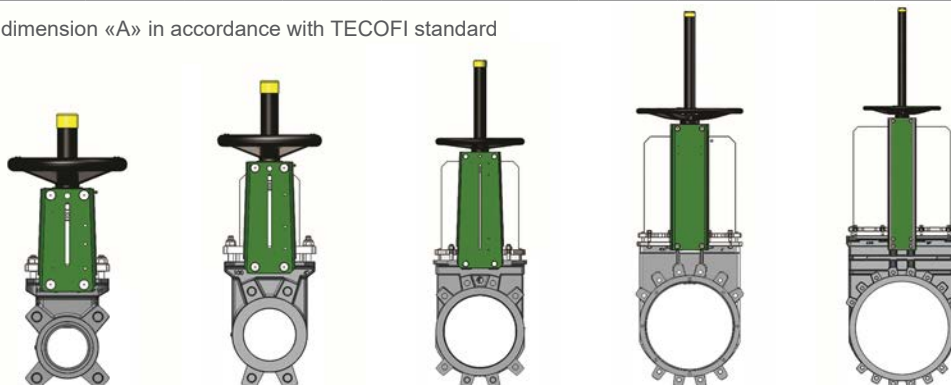

Tecofi France

83 rue Marcel Mérieux - 69960 Corbas
 Tél. +33 (0)4 72 79 05 79 - Fax. +33 (0)4 78 90 19 19
 E-mail : sales@tecofi.fr - www.tecofi.fr



KNIFE GATE VALVE STAINLESS STEEL BODY

TECHNICAL PASSPORT

VG 6400-00

WORKING CONDITIONS

Maximum working pressure: DN50-250 : 10 bar
DN300-450 : 7 bar
DN500-600 : 4 bar

Maximum working temperature : -10°C / +130°C (EPDM joint in standard)

! The above mentioned pressures are only valid if the direction of assembly indicated by the arrow on the valves is observed.

Upstream/downstream tightness



Elastomer tightness

Metal/metal tightness

Packing tightness

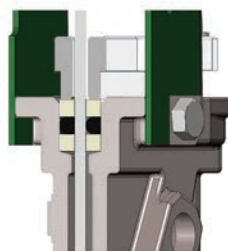

PTFE/Elastomer

Tightness in option

Tightness	Maximum temperature
Metal/metal	Tmax : -10°C / +130°C
NBR	Tmax : -10°C / +80°C
White EPDM	Tmax : -10°C / +130°C
Silicone	Tmax : -10°C / +170°C
FPM (Type Viton®)	Tmax : -10°C / +170°C
PTFE	Tmax : +4°C / +170°C
CSM (Type Hypalon®)	Tmax : +4°C / +80°C

! To ensure a satisfactory tightness, when using the PTFE gasket, the operating pressure must be at least 1 bar.

FLOWS

Kv of valves (m³/h)

DN		Operating stroke, %									
mm	inch	10%	20%	30%	40%	50%	60%	70%	80%	90%	100%
50	2"	1,41	7,57	18,4	33,27	52,61	74,78	98,45	120,81	149,53	161,66
65	2 1/2"	2,41	8,58	25,4	49,32	85,77	121,51	167,85	219,67	287,45	317,77
80	3"	3	13,1	46,66	79,57	122,11	199,58	276,85	359,84	432,49	461,98
100	4"	3,86	33,06	75,62	125,01	206,17	311,72	474,43	681,36	865,17	993,21
125	5"	19,64	47,05	107,47	177,8	295,95	444,71	675,13	973,05	1231,14	1385,15
150	6"	28,88	104,25	181,37	281,61	418,76	614,83	884,79	1177,11	1482,44	1613,77
200	8"	24,04	141,73	251,71	418,72	514,76	785,11	1227,16	1982,56	2491,22	2783,27
250	10"	115,44	367,52	693,84	1141,65	1634,09	2342,79	3243,71	3960,67	5336,19	5951,8
300	12"	103,12	535,87	1023,55	1619,5	2441,26	3508,29	4553,83	6339,29	7862,36	8373,88
350	14"	218,4	725,8	1323	2173,2	3294,8	4914,3	7120,9	11415,3	19105,4	24890,7
400	16"	389,1	1150,1	2024,4	3130,9	4669,6	7009,1	10355,2	16014,2	22600,5	26497,7
450	18"	402,7	1287,3	2402,9	3803,4	5686,8	8247,3	12248,7	17298,5	26403,9	29485
500	20"	617	1611,1	2935,9	4625,8	7054,7	10438,9	15446	23582,8	35107,4	42784

Tecofi France

83 rue Marcel Mérieux - 69960 Corbas
Tél. +33 (0)4 72 79 05 79 - Fax. +33 (0)4 78 90 19 19
E-mail : sales@tecofi.fr - www.tecofi.fr

